

## TECHNICAL DATA SHEET

### 90° 450x450 AMBULANT GRAB RAIL

AS1428.1 COMPLIANT

STAINLESS STEEL

5 YEAR FINISH WARRANTY

#### PRODUCT CODE

SAB-GR-AMB-SSS

#### PRODUCT FEATURES

The SABRE range of grab rails have been developed to meet the safety requirements to assist those with physical disabilities while maintaining compliance with the Australian Standard AS1428.1. Our stainless steel grab rails contain 5 fixing position mounting plates with secure push on, twist and lock cover to provide easy installation to various surfaces.

#### TECHNICAL DETAILS

AS1428.1 Compliant	Yes
Material	304 Stainless Steel
Finish	Satin Stainless Steel
Rails	Ø32mm x 1.2mm full round diameter
Fixing	Ø75mm mounting plates with 5 fixing locations
Covers	Ø77mm push, twist and lock mounting plate covers
Fixing Screws	10g x 50mm stainless steel Phillips pan head fixing screws (x10)

#### INSTALLATION

It's important to note that the appropriate wall preparation is made for the location of each fixing point to ensure that the rail is firmly secured to the wall to support the intended use of this product.

When AS1428.1 Design for Access and Mobility compliance is required, the installer should ensure all grab rail installation criteria for the Australia Standard are satisfied.

**Note:** Alternate fasteners or anchors other than those supplied may be needed to suit wall materials to ensure firm installation that will meet attachment and strength requirements.

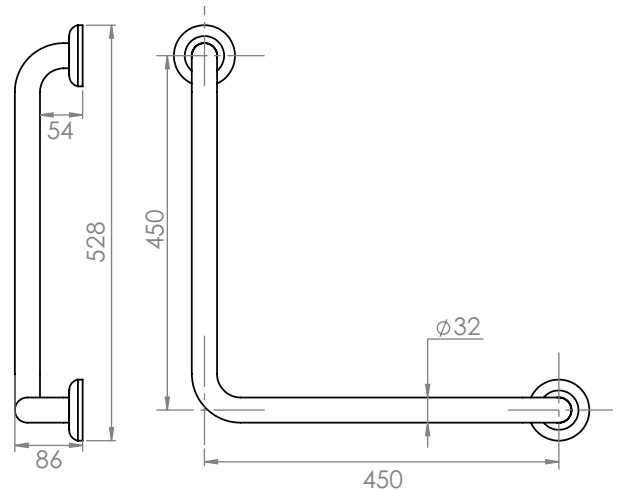

Dimensions may vary slightly from product to product. Check before installation.

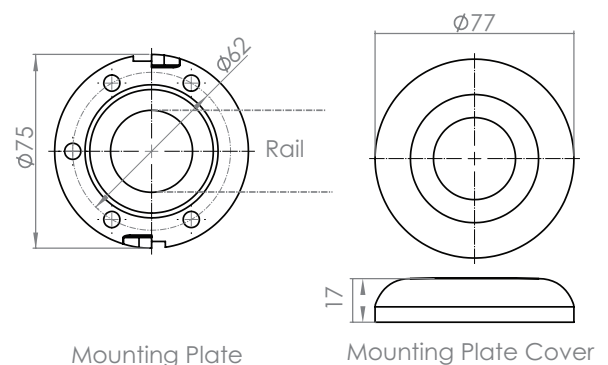

Mounting Plate

Mounting Plate Cover

